

PREPARED BY: _____ DATE _____

APPROVED BY: _____ DATE _____

SHARP

LIQUID CRYSTAL DISPLAY GROUP
SHARP CORPORATION

SPECIFICATION

SPEC No. LC94805#

FILE No. _____

ISSUE OCT. 5.1994

PAGE 23 Pages

APPLICABLE DIVISION

DUTY PANEL DEVELOPMENT CENTER

TFT DEVELOPMENT CENTER

LCD PRODUCTS DEVELOPMENT CENTER

EL PRODUCTION DEPT.

DEVICE SPECIFICATION for
Passive Matrix COLOR LCD Unit
(640×480 dots)

Model No.
LM64C35P

CUSTOMER'S APPROVAL

DATE _____

BY _____

PRESENTED
BY Y. Inoue
Y. Inoue
DEPARTMENT GENERAL MANAGER
ENGINEERING DEPARTMENT II
DUTY PANEL DEVELOPMENT CENTER
LIQUID CRYSTAL DISPLAY GROUP
SHARP CORPORATION

SHARP

SPEC No.
LC94805³ #

MODEL No.
LM64C35P

DOC. FIRST ISSUE
OCT. 5. 1994

IDENT. DATA No.

RECORDS OF REVISION

DATE	REF. PAGE PARAGRAPH DRAWING No.	REVISED No.	SUMMARY	CHECK & APPROVAL
OCT. 5.1994	Page 4	△	DELETED (Input capacitance)	<i>Y. Inoue</i>
OCT. 5.1994	Page 1,11,20	△	REVISED (Table No.)	
OCT. 5.1994	Page 18	△	REVISED (Characteristics of Backlight)	
Mar.13.1995	Page 22	△	ADDED	<i>Y. Inoue</i>

1. Application

This data sheet is to introduce the specification of LM64C35P, Passive Matrix type Color LCD Unit.

2. Construction and Outline

Construction: 640×480 dots color display unit consisting of an LCD panel, PWB(printed wiring board) with electric components mounted onto, TAB(tape automated bonding) to connect the LCD panel and PWB electrically, and plastic chassis with CCFT back light and bezel to fix them mechanically.

Signal ground(VSS) is connected with the metal bezel.

DC/DC converter is built in.

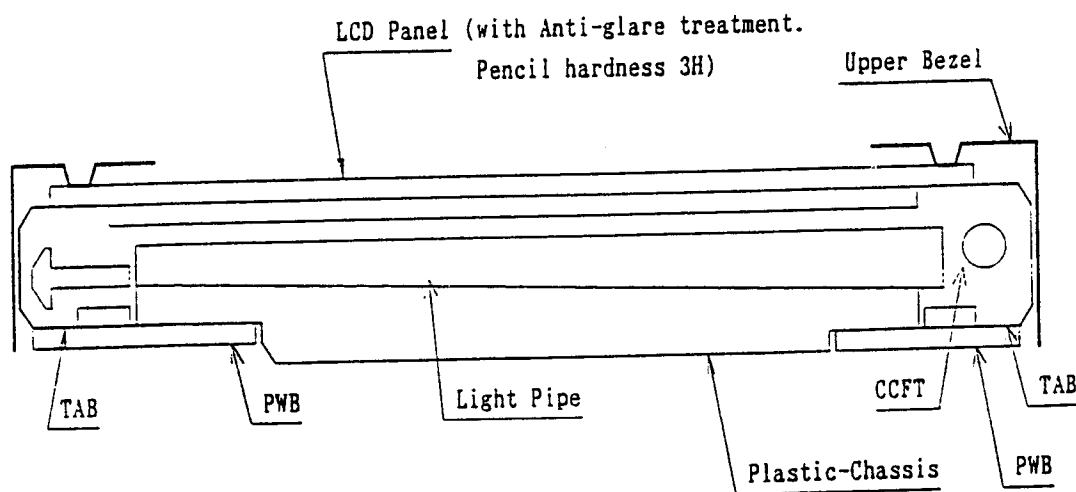

Outline : See Fig. 10 
Connection : See Fig. 10 and Table 7

3. Mechanical Specifications

Table 1

Parameter	Specifications	Unit
Outline dimensions	242.5(W)×179.4(H)×11.5MAX(D)	mm
Effective viewing Area	214.2(W)×161.4(H)	mm
Display format	640(W)×480(H) full dots	—
Dot size	0.085×RGB(W)×0.305(H)	mm
Dot spacing	0.025	mm
*1 Base color	Normally black *2	—
Weight	Approx. 500	g

*1 Due to the characteristics of the LC material, the colors vary with environmental temperature.

*2 Negative-type display

Display data "H" : ON → transmission

Display data "L" : OFF → light isolation

4. Absolute Maximum Ratings

4-1 Electrical absolute maximum ratings

Table 2

Parameter	Symbol	MIN.	MAX.	Unit	Remark
Supply voltage (Logic)	$V_{DD}-V_{SS}$	0	6.0	V	Ta=25 °C
Input voltage	V_{IN}	-0.3	$V_{DD}+0.3$	V	Ta=25 °C

4-2 Environmental Conditions

Table 3

Item	Tstg		Topr		Remark
	MIN.	MAX.	MIN.	MAX.	
Ambient temperatuer	-25 °C	+60 °C	0 °C	+40 °C	Note 4)
Humidity	Note 1)		Note 1)		No condensation
Vibration	Note 2)		Note 2)		3 directions (X/Y/Z)
Shock	Note 3)		Note 3)		6 directions ($\pm X \pm Y \pm Z$)

Note 1) $T_a \leq 40$ °C.....95 % RH Max
 $T_a > 40$ °C.....Absolute humidity shall be less than $T_a = 40$ °C/95 % RH.

Note 2)

Table 4

Frequency	10 Hz ~ 57 Hz	57 Hz ~ 500 Hz
Vibration level	-	9.8 m/s ²
Vibration width	0.075 mm	-
Interval	10 Hz ~ 500 Hz ~ 10 Hz / 11.0 min	

2 hours for each direction of X/Y/Z (6 hours as total)

Note 3) Accerelation : 490 m/s²
 Pulse width : 11 ms
 3 times for each direction of $\pm X / \pm Y / \pm Z$

Note 4) Care should be taken so that the LCD Unit may not be subjected to the temperature out of this specification.

5. Electrical Specifications
5-1 Electrical characteristics

Table 5

Ta=25 °C, V_{DD}=5 V±10 %

Parameter	Symbol	Conditions	Min.	Typ.	Max.	Unit
Supply voltage (Logic)	V _{DD} -V _{SS}	Note 1)	4.5	5.0	5.5	V
Contrast adjust voltage	V _{CON} -V _{SS}	Ta=0 °C	0.8	—	—	V
		Ta=25 °C	1.35	1.95	2.55	V
		Ta=40 °C	—	—	2.80	
Input signal voltage	V _{IN}	"H" level	0.8V _{DD}	V _{DD}	V _{DD} +0.3	V
		"L" level	-0.3	V _{SS}	0.2V _{DD}	V
Input leakage current	I _{IL}	"H" level	—	—	1.0	μA
		"L" level	-1.0	—	—	μA
Supply current (Logic)	I _{DD}	Note 2)	—	160	240	mA
Rush current (Logic)	I _{RUSH}	Ta=25 °C, Power ON	3 A(pk)×25 ms+1 A(pk)×10 μs max			
Power consumption	P _d	Note 2)	—	800	1 320	mW

Note 1) Under the following conditions.;

- ①Immediately after the rise of DISP signal. : 3 A×25 ms
- ②Under the situation that DISP signal is on and kept steady.: 1 A×10 μs

Note 2) Under the following conditions.;

V_{CON}-V_{SS} : contrast max.(1.95 V TYP)

V_{DD}-V_{SS}=5 V, Frame frequency=73 Hz, Display pattern = black/white stripe pattern.

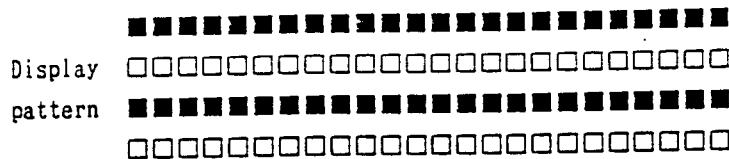

This value is direct current.

5-3 Interface signals

○LCD

Table 7

Pin No	Symbol	Description	Level
1	DL4	Display data signal (Lower)	H(ON), L(OFF)
2	V _{SS}	Ground potential	—
3	DL5	Display data signal (Lower)	H(ON), L(OFF)
4	YD	Scan start-up signal	"H"
5	DL6	Display data signal (Lower)	H(ON), L(OFF)
6	LP	Input data latch signal	"H"→"L"
7	DL7	Display data signal (Lower)	H(ON), L(OFF)
8	V _{SS}	Ground potential	—
9	V _{SS}	Ground potential	—
10	XCK	Data input clock signal	"H"→"L"
11	DLO	Display data signal (Lower)	H(ON), L(OFF)
12	V _{COM}	Contrast adjust voltage	—
13	DL1	Display data signal (Lower)	H(ON), L(OFF)
14	V _{DD}	Power supply for logic and LCD (+5V)	—
15	V _{SS}	Ground potential	—
16	V _{DD}	Power supply for logic and LCD (+5V)	—
17	DL2	Display data signal (Lower)	H(ON), L(OFF)
18	DISP	Display control signal	H(ON), L(OFF)
19	DL3	Display data signal (Lower)	H(ON), L(OFF)
20	NC	—	—
21	V _{SS}	Ground potential	—
22	DU3	Display data signal (Upper)	H(ON), L(OFF)
23	DU4	Display data signal (Upper)	H(ON), L(OFF)
24	DU2	Display data signal (Upper)	H(ON), L(OFF)
25	DU5	Display data signal (Upper)	H(ON), L(OFF)
26	DU1	Display data signal (Upper)	H(ON), L(OFF)
27	V _{SS}	Ground potential	—
28	DU0	Display data signal (Upper)	H(ON), L(OFF)
29	DU6	Display data signal (Upper)	H(ON), L(OFF)
30	V _{SS}	Ground potential	—
31	DU7	Display data signal (Upper)	H(ON), L(OFF)

○CCFT

Pin No	Symbol	Description	Level
1	HV	High voltage lineal (from Inverter)	—
2	NC	—	—
3	GND	Ground line (from Inverter)	—

NOTE) Pin No. and its location are shown in Fig.10.

○LCD

Used connector:DF9B-31P-1V (HIROSE)

Mating connector:DF9B-31S-1V (HIROSE)

○CCFT

Used connector:BHR-03VS-1 (JST)

Mating connector:SM03(4.0)B-BHS or SM02(8.0)B-BHS (JST)

Except above connector shall be out of guaranty

SHARP

SPEC No. LC94805	MODEL No. LM64C35P	PAGEZ 6
---------------------	-----------------------	------------

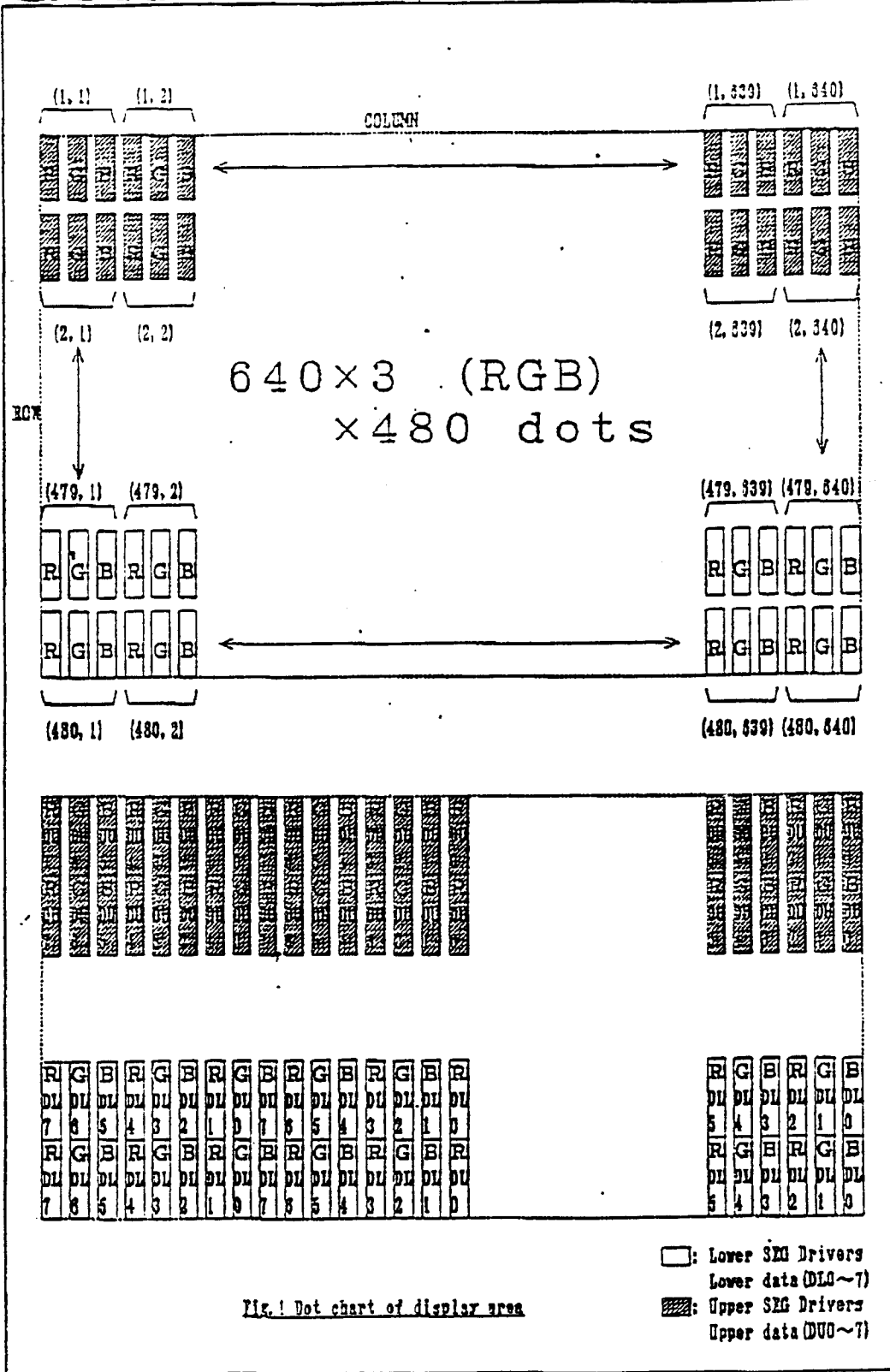

Fig. 1 Dot chart of display area

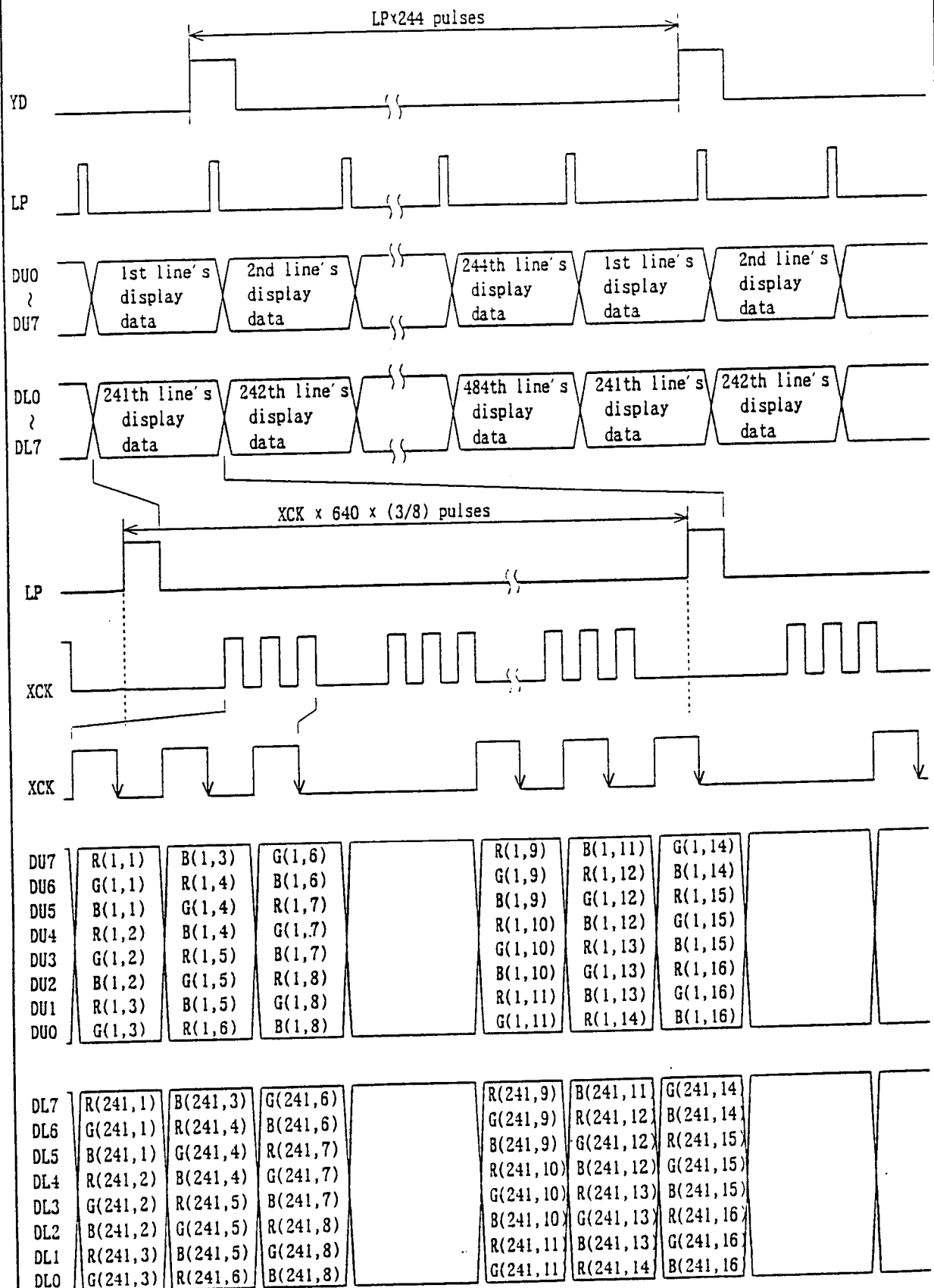

Fig.2 Data input timing chart

Table 8 Interface timing ratings

Item	Symbol	Rating			Unit
		MIN.	TYP.	MAX.	
Frame cycle *1	tFRM	8.33		16.94	ms
YD signal "H" level set up time	tHYS	100			ns
"H" level hold time	tHYH	100			ns
"L" level set up time	tLYS	100			ns
"L" level hold time	tLYH	40			ns
LP signal "H" level pulse width	tWLPH	200			ns
XCK signal clock cycle	tCK	82			ns
"H" level clock width	tWCKH	30			ns
"L" level clock width	tWCKL	30			ns
Data set up time	tDS	30			ns
hold time	tDH	30			ns
LP ↑ allowance time from XCK ↓	tLS	200			ns
XCK ↑ allowance time from LP ↓	tLH	200			ns
Input signal rise/fall time	tr,tf			13	ns

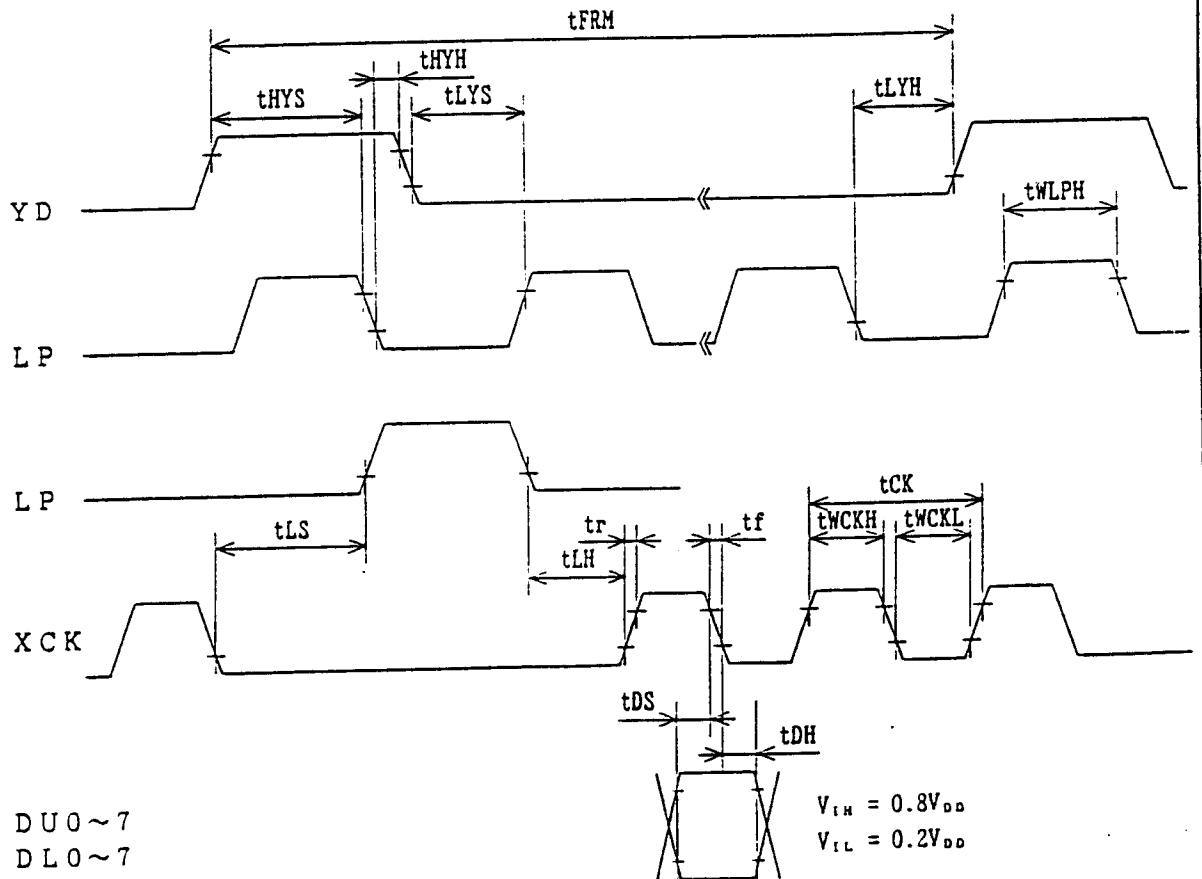

Fig.3 Interface timing chart

SHARP

SPEC No.

LC94805B

MODEL No.

LM64C35P

PAGE

9

*1 LCD unit functions at the minimum frame cycle of 8.33 ms (Maximum frame frequency of 120 Hz).

Owing to the characteristics of LCD unit, "shadowing" will become more eminent as frame frequency goes up, while flicker will be reduced.

According to our experiments, frame cycle of 12.8 ms Min. or frame frequency of 78 Hz Max. will demonstrate optimum display quality in terms of flicker and "shadowing". But since judgement of display quality is subjective and display quality such as "shadowing" is pattern dependent, it is recommended that decision of frame frequency, to which power consumption of the LCD unit is proportional, be made based on your own through testing on the LCD unit with every possible patterns displayed on it.

※ The intervals of one LP fall and the next must be always the same, and LPs must be input continuously.

The interval must be 70 μ s Max.

6. Unit Driving Method

6.1 Circuit configuration

Fig.10 shows the block diagram of the Unit's circuitry.

6.2 Display Face Configuration

The display consists of 640×3 (R,G,B) $\times 480$ dots as shown in Fig.1.

The interface is single panel with double drive to be driven at 1/244 duty ratio.

6.3 Input Data and Control Signal

The LCD driver is 160 bits LSI, consisting of shift registers, latch circuits and LCD driver circuits. Input data for each row (640×3 R,G,B) will be sequentially transferred in the form of 8 bit parallel data through shift registers from top left of the display together with clock signal(XCK)

When input of one row (640×3 , R,G,B dots) is completed, the data will be latched in the form of parallel data corresponding to the signal electrodes by the falling edge of latch signal (LP). Then, the corresponding drive signals will be transmitted to the 640×3 lines of column electrodes of the LCD panel by the LCD drive circuits.

At this time, scan start-up signal (YD) has been transferred from the scan signal driver to the 1st row of scan electrodes, and the contents of the data signals are displayed on the 1st row of the display face according to the combinations of voltages applied to the scan and signal electrodes of the LCD. While the data of 1st row are being displayed, the data of 2nd row are entered. When data for 640×3 dots have been transferred, they will be latched by the falling edge of LP, switching the display to the 2nd row.

Such data input will be repeated up to the 244th row of each display segment, from upper row to lower rows, to complete one frame of display by time sharing method.

Simultaneously the same scanning sequence occur at the lower panel. Then data input proceeds to the next display frame.

YD generates scan signal to drive horizontal electrodes.

Since DC voltage, if applied to LCD panel, causes chemical reaction in LC materials, causing deterioration of the materials, drive wave-form shall be inverted at every display frame to prevent the generation of such DC voltage. Control Signal M plays such a role.

Because of the characteristics of the CMOS driver LSI, the power consumption of the display unit goes up with the clock frequency of XCK.

To minimize data transfer speed of XCK clock the LSI has the system of transferring 8 bit parallel data through the 8 lines of shift registers.

Thanks to this system the power consumption of the display unit is minimized.

In this circuit configuration, 8 bit display data shall input to data input pins of DU0~7 and DLO~7.

Furthermore, the display unit has bus line system for data input to minimize the power consumption with data input terminals of each driver LSI being activated only when relevant data input is fed.

Data input for column electrodes and chip select of driver LSI are made as follows:

The driver LSI at the left end of the display face is first selected, and the adjacent driver LSI right next side is selected when data of 160 dot (20XCK) is fed. This process is sequentially continued until data is fed to the driver LSI at the right end of the display face. This process is followed simultaneously both at the top and bottom column drivers LSI's.

Thus data input will be made through 8 bit bus line sequentially from the left end of the display face.

Since this display unit contains no refresh RAM, it requires the above data and timing pulse inputs even for static display.

The timing chart of input signals are shown in Fig. 3 and Table 8.

7. Optical Characteristics

$T_a = 25\text{ }^\circ\text{C}, V_{OD} = 5.0\text{ V}, V_{con} - V_{SS} = V_{max}$

Table 9

Following spec are based upon the electrical measuring conditions, on which the contrast of perpendicular direction ($\theta_x = \theta_y = 0^\circ$) will be MAX.

Parameter	Symbol	Condition	MIN.	TYP.	MAX.	Unit	Remark	
Viewing angle range	θ_x	$Co > 5.0$	$\theta_y = 0^\circ$	-30	-	30	dgr.	Note1)
	θ_y		$\theta_x = 0^\circ$	-15	-	25	dgr.	
Contrast ratio	Co	$\theta_x = \theta_y = 0^\circ$	15	30	-	-	Note2)	
Response time	Rise	$\theta_x = \theta_y = 0^\circ$	τ_r	-	220	300	ms	Note3)
	Decay			τ_d	-	80	100	
Unit chromaticity	White	$\theta_x = \theta_y = 0^\circ$	x	-	0.275	-	-	
				y	-	0.320	-	

Note 1) The viewing angle range is defined as shown Fig.4.

Note 2) Contrast ratio is defined as follows:

$$Co = \frac{\text{Luminance(brightness) all pixels "White" at } V_{max}}{\text{Luminance(brightness) all pixels "dark" at } V_{max}}$$

V_{max} is defined in Fig.6.

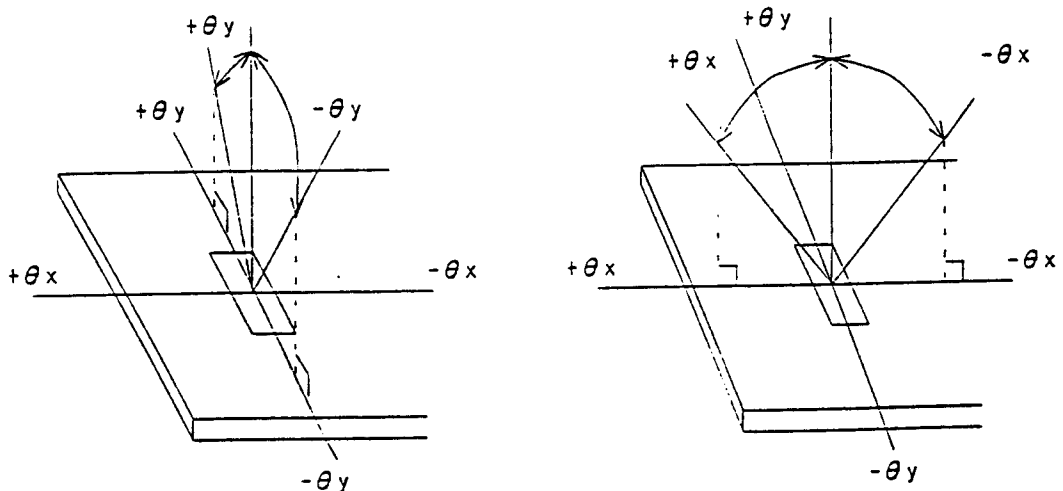

Fig.4 Definition of Viewing Angle

Note 3) The response characteristics of photo-detector output are measured as shown in Fig.7, assuming that input signals are applied so as to select and deselect the dots to be measured, in the optical characteristics test method shown in Fig.8.

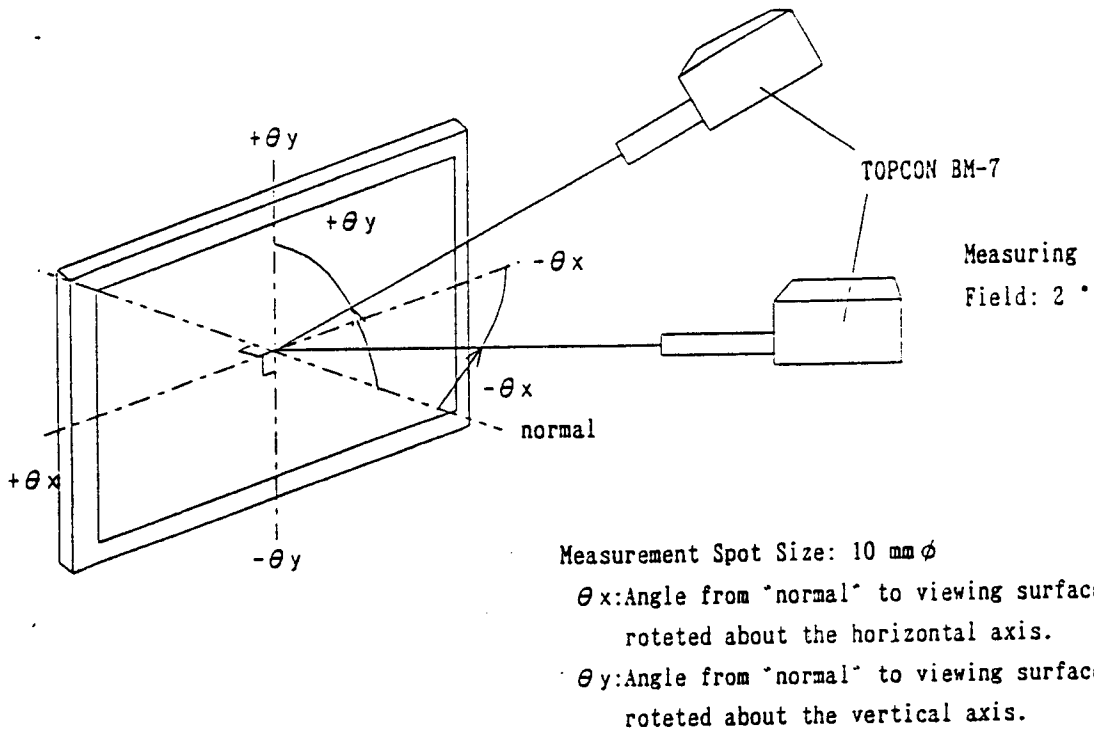

Fig. 5 Optical Characteristics Test Method I

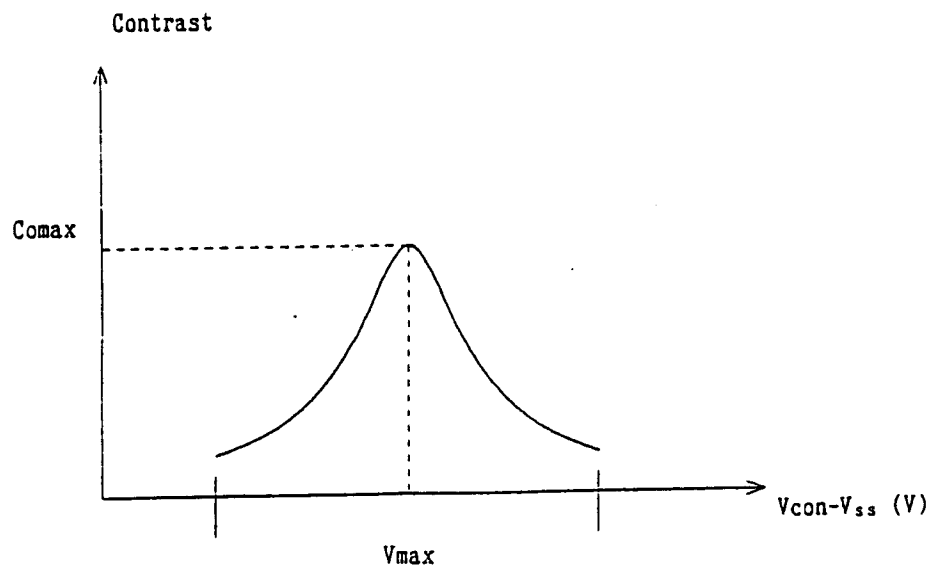

Fig. 6 Definition of V_{max}

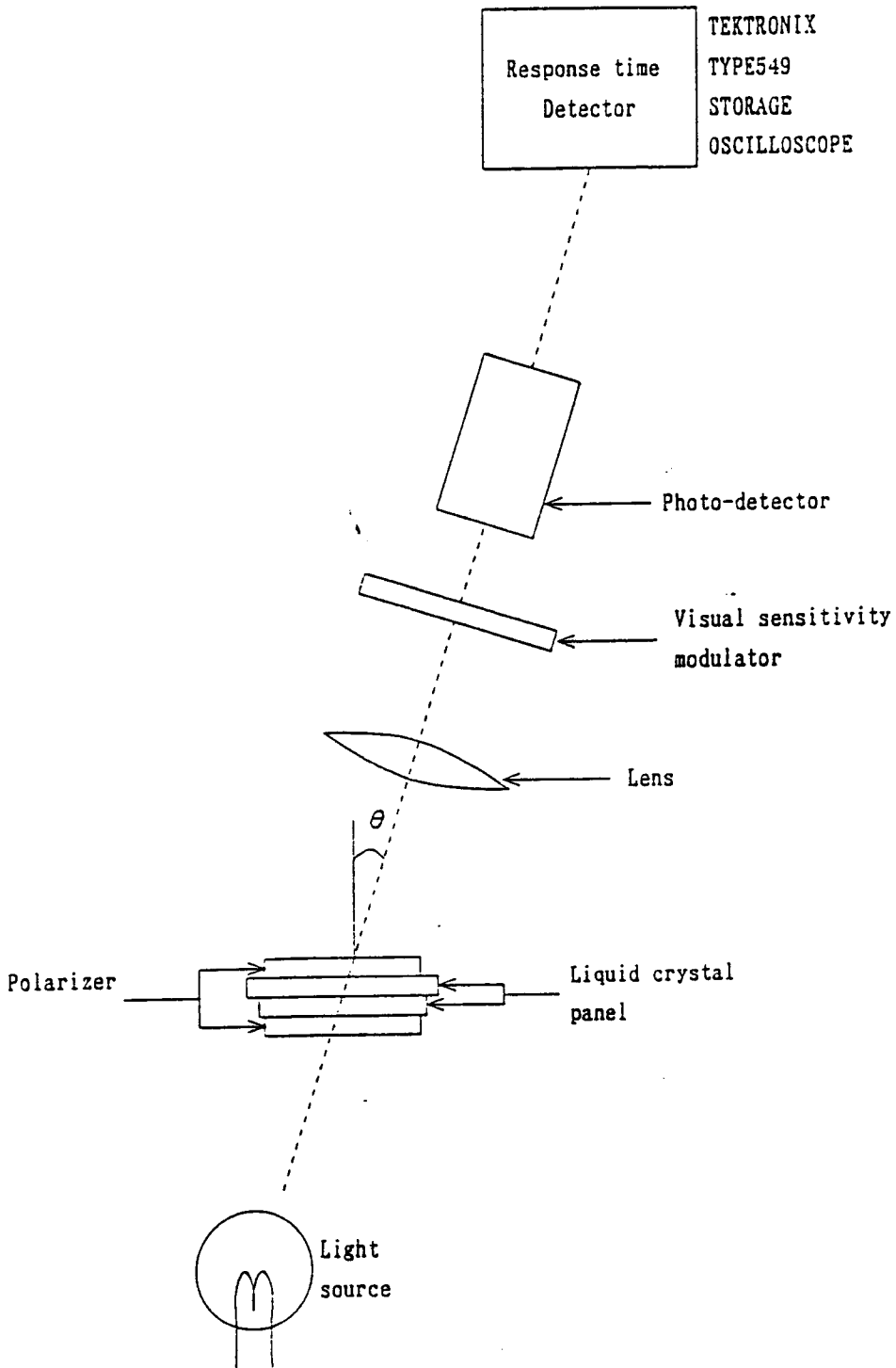

Fig.7 Optical Characteristics Test Method II

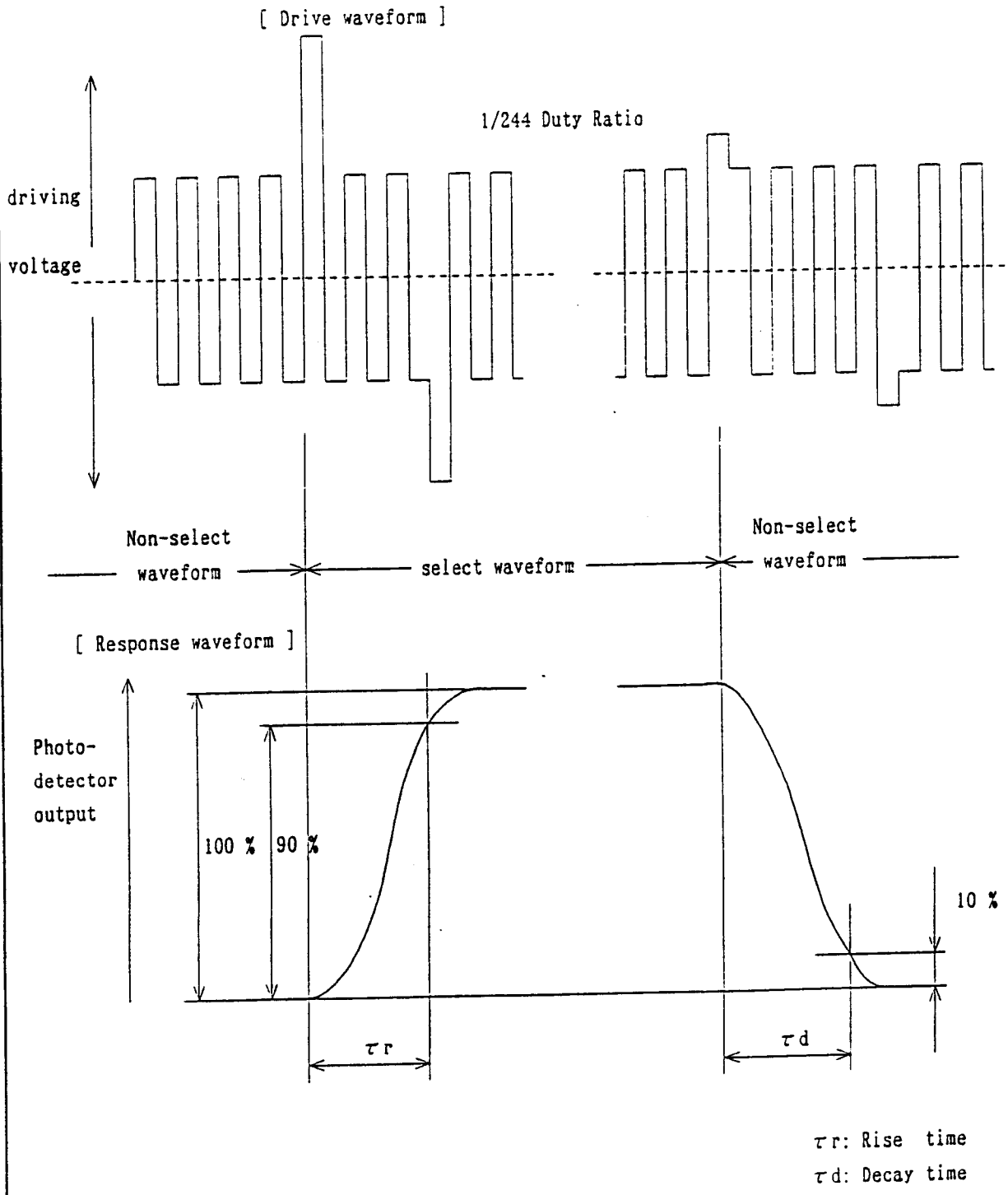

Fig.8 Definition of Response Time

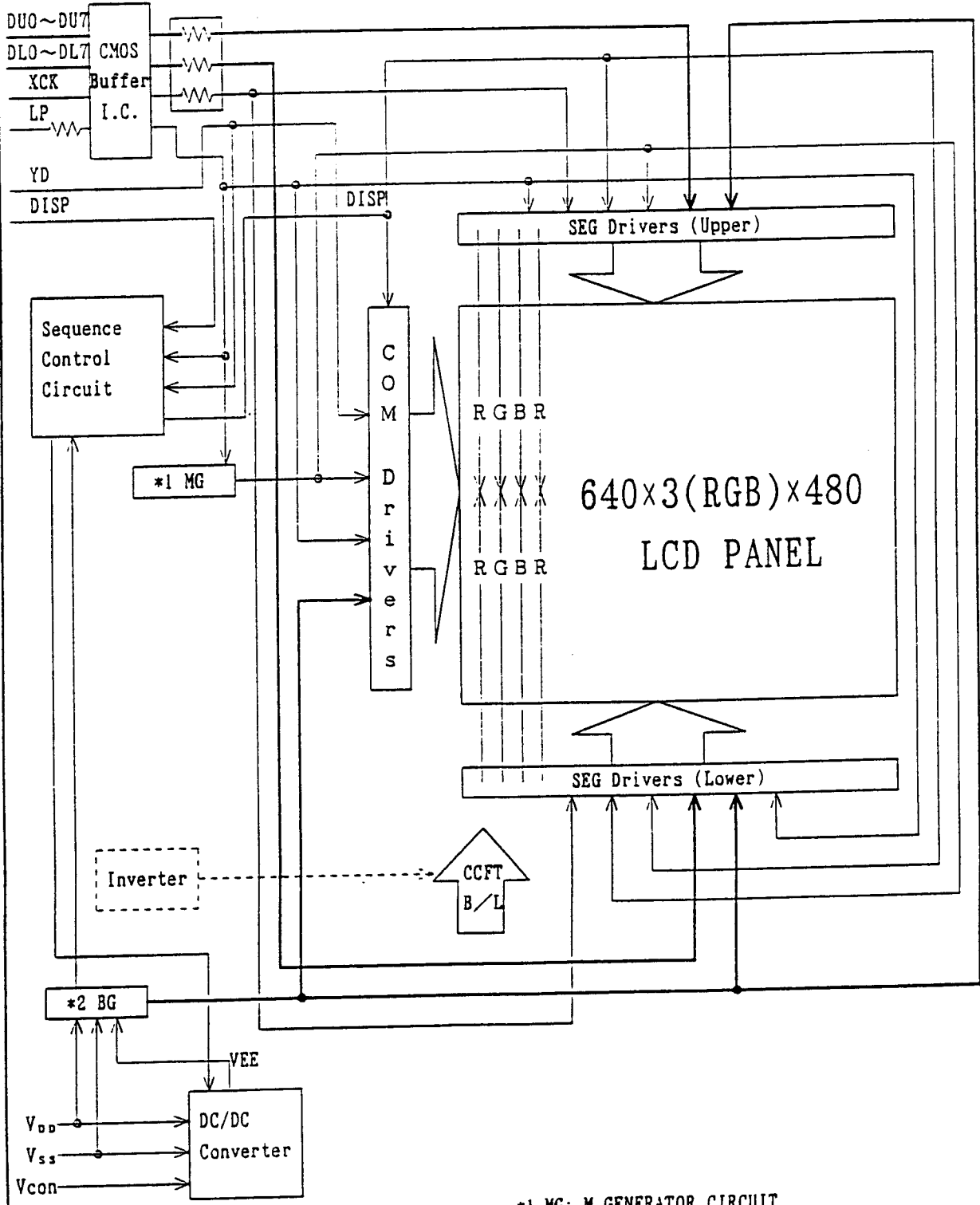
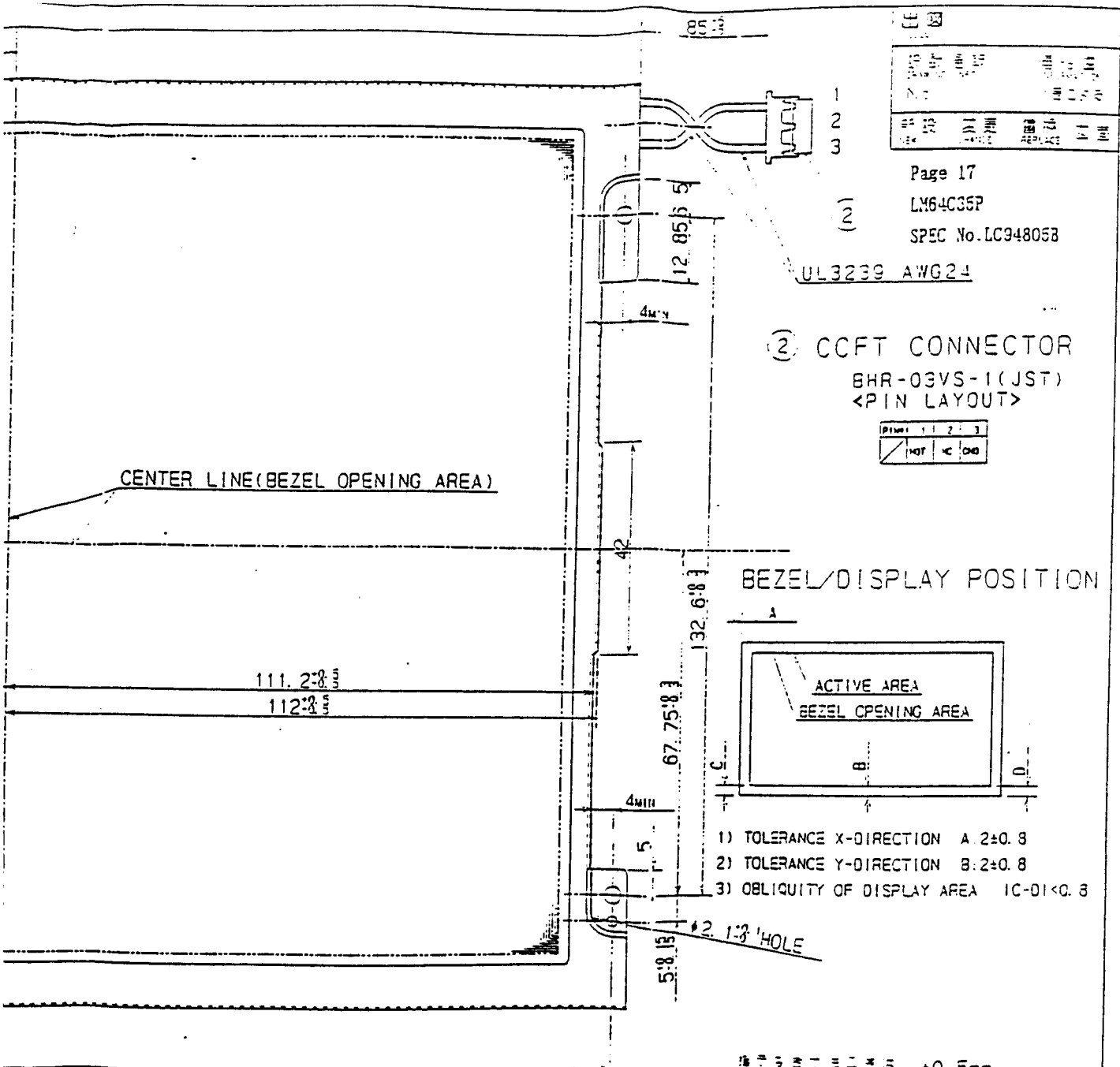

Fig.9 Circuit block diagram

*1 MG: M GENERATOR CIRCUIT
*2 BG: BIAS GENERATOR & PROTECTION CIRCUIT



Page 17
 LM64C35P
 SPEC No. LC948058

② CCFT CONNECTOR
 BHR-03VS-1 (JST)
 <PIN LAYOUT>

PIN#	1	2	3
	HOT	GND	CH0

BEZEL/DISPLAY POSITION

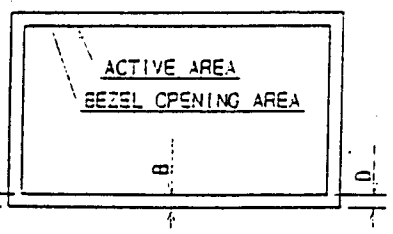

- 1) TOLERANCE X-DIRECTION A ± 0.8
- 2) TOLERANCE Y-DIRECTION B: ± 0.8
- 3) OBLIQUITY OF DISPLAY AREA $1C-D1 < 0.8$

±0.5mm

LM64C35P		NAME	LCD UNIT OUTLINE DIMENSIONS
		SIZE	640xP-G-5x480DOTS 1/240 DUTY
SHARP CORPORATION		DATE	1994 2 23
シャープ株式会社 (株) (東京)		DRAWING NO.	0010-4-73
URATAHI	11-179		

Fig.10 OUTLINE DIMENSIONS

8.Characteristics of Backlight

The ratings are given on condition that the following conditions are satisfied.

1) Rating (Note)

Parameter	Min	Typ	Max	Unit
Brightness	50	70	-	cd/m ²

2) Measurement circuit: CXA-M10L (TDK) (at IL=5.4 mArms)

3) Measurement equipment: BM-7 (TOPCON Corporation)

4) Measurement conditions

4-1 Measurement circuit voltage: DC=9.6 V, at primary side

4-2 LCD: All digits WHITE, V_{DD}= 5 V, V_{con}-V_{ss}=V_{max}, DU0~7="H"(WHITE), DLO~7="H"(WHITE)

4-3 Ambient temperature: 25 °C

Measurement shall be executed 30 minutes after turning on.

5) Used lamp: HMBS25D10W217C/X HARISON ELECTRIC CO.,LTD. : 1 pc

5-1 Rating

Parameter	Symbol	Min.	Typ.	Max.	Unit	Remark
Lamp voltage	V _L	-	480	-	V _{rms}	-
Lamp current	I _L	3.8	5.4	6.0	mArms	(*1)
Lamp power consumption	P _L	-	2.6	-	W	(*2)
Lamp frequency	F _L	20	-	50	kHz	-
Kick-off voltage	V _s	-	-	900	V _{rms}	Ta=25°C
		-	-	1100	V _{rms}	Ta=0°C (*3)
Lamp life time	L _L	10000	-	-	h	-

Within no conductor closed. (CCFT only)

(*1) It is recommended that IL be not more than 5.4 mArms so that heat radiation of CCFT backlight may least affect the display quality.

(*2) Power consumption excluded inverter loss.

(*3) The circuit voltage(VS) of the inverter should be designed to have some margin(reference value:1 450 V_{rms}MIN),because VS may be increased due to the leak current in case of the LCD unit.

5-2 Operating life

The operating life time is 10 000 hours or more at 5.4 mA.

(Operating life with CXA-M10L-L or equivalent.)

The inverter should meet the following conditions to keep the specified life time of used lamp;

-Sine, symmetric waveform without spike in positive and negative.

-Output frequency range: 20 KHz~50 KHz

Make sure the operating conditions by executing the burn-in enough time.

The operating life time is defined as having ended when any of the following conditions occur; $25 \pm 1 \text{ }^\circ\text{C}$

- When the voltage required for initial discharge has reached 110 % of the initial value
- When the illuminence or quantity of light has decreased to 50 % of the initial value

(NOTE) Rating are defined as the average brightness inside the viewing area specified in Fig.11.

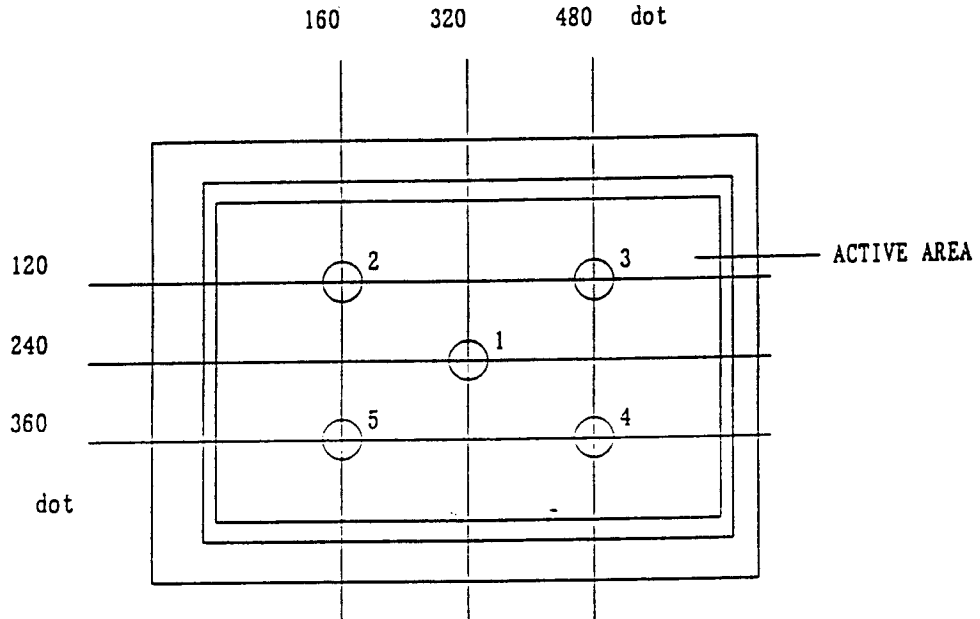

Fig.11 Measureing points (1~5)

9. Precautions

- 1) Industrial (Mechanical) design of the product in which this LCD unit will be incorporated must be made that the viewing angle characteristics of the LCD may be optimized.

This unit's viewing angle is illustrated in Fig.12.

$$\theta y \text{ MIN} < \text{viewing angle} < \theta y \text{ MAX}$$

(For the specific values of θy_{min} , θy_{max} , refer to the table 9.)

Please consider the optimum viewing conditions according to the purpose when installing the unit.

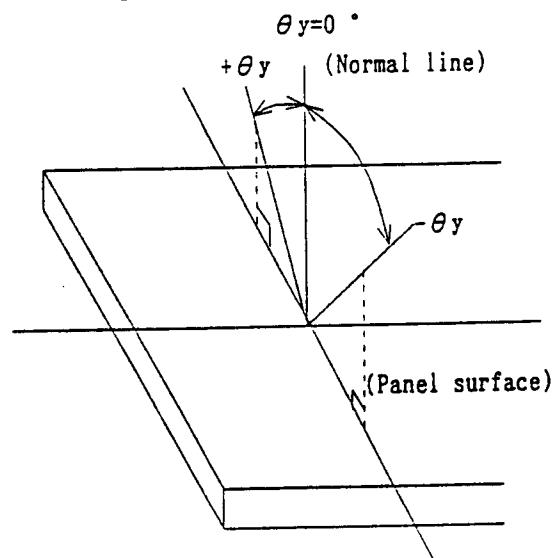

Fig.12 Dot matrix LCD viewing angle

- 2) This unit is installed using mounting holes metal PBC or bezel.
When installing the unit, pay attention and handle carefully not to allow any undue stress such as twist or bend.
A transparent acrylic resin board or other type of protective panel should be attached to the front of the unit to protect the polarizer, LCD cells, etc.

- 3) Since the front polarizer is easily damaged. Please pay attention not to scratch on its face.
- 4) If the surface of the LCD cells needs to be cleaned, wipe it swiftly with cotton or other soft cloth. If still not completely clear, blow on its and wipe.
- 5) Water droplets, etc, must be wiped off immediately since they may cause color changes, staining, etc, if remained for a long time.
- 6) Since LCD is made of glass plates, dropping the unit or banging it against hard objects may cause cracking or fragmentation.
- 7) CMOS LSIs are equipped in this unit, so care must be taken to avoid the electro static charge, by earthing human body, etc. Take the following measures, to protect the unit from the electric discharge via mounting tabs from the main system the electrified with static electricity.
 - (1) Earth the metallic case of the main system (contact of the unit and main system).
 - (2) Insulate the unit and main system by attaching insulating washers made of bakelite or nylon, etc.
- 8) The unit should be driven according to the specified ratings to avoid malfunction of permanent damage. DC voltage drive leads to rapid deterioration of LC, so ensure that the drive is alternating waveform by continuous application of the signal M. Especially the power ON/OFF sequence shown on next page is strongly recommended to avoid latch-up of drive LSIs and application of DC voltage to LCD panel.
- 9) Since leakage current, which may be caused by routing of CCFT cables, etc., may affect the brightness of the display, the inverter has to be designed taking the leakage current into consideration. Thorough evaluation of the LCD unit/inverter built into its host equipment shall be conducted, therefore, to ensure the specified brightness.
- 10) Avoid to expose the unit to the direct sun-light, strong ultraviolet light, etc. for a long time.
- 11) If stored at temperatures below specified storage temperature, the LC may freeze and be deteriorated. If storage temperature exceed the specified rating. the molecular orientation of the LC may change to that of a liquid, and they may not revert to their original state. As for as possible always store at normal room temperature.
- 12) Disassembling the LCD unit can cause permanent damage and should be strictly avoided.



13) How to insert interface connector

When the interface connector is inserted, it should be parallel to the connector of LCD module and it should be inserted horizontally.

When the connector is attempted to be fixed to LCD connector, it should be inserted properly in order not to create a gap as shown "A".

Please insert the connector as both edge is placed to the connect position of LCD connector.

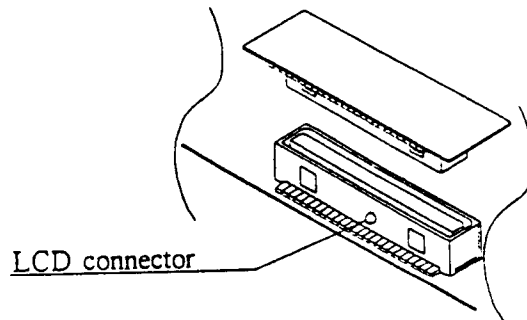
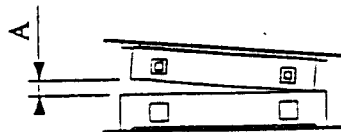
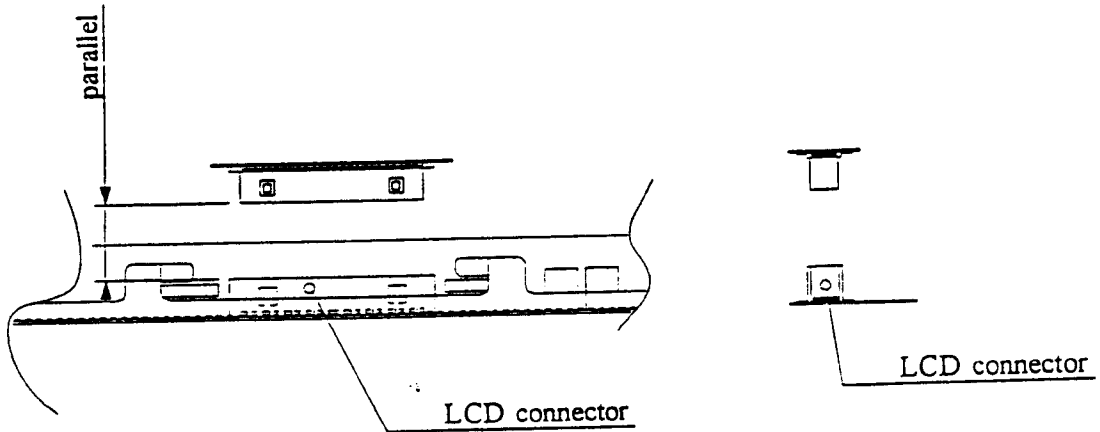

Supply voltage sequence condition

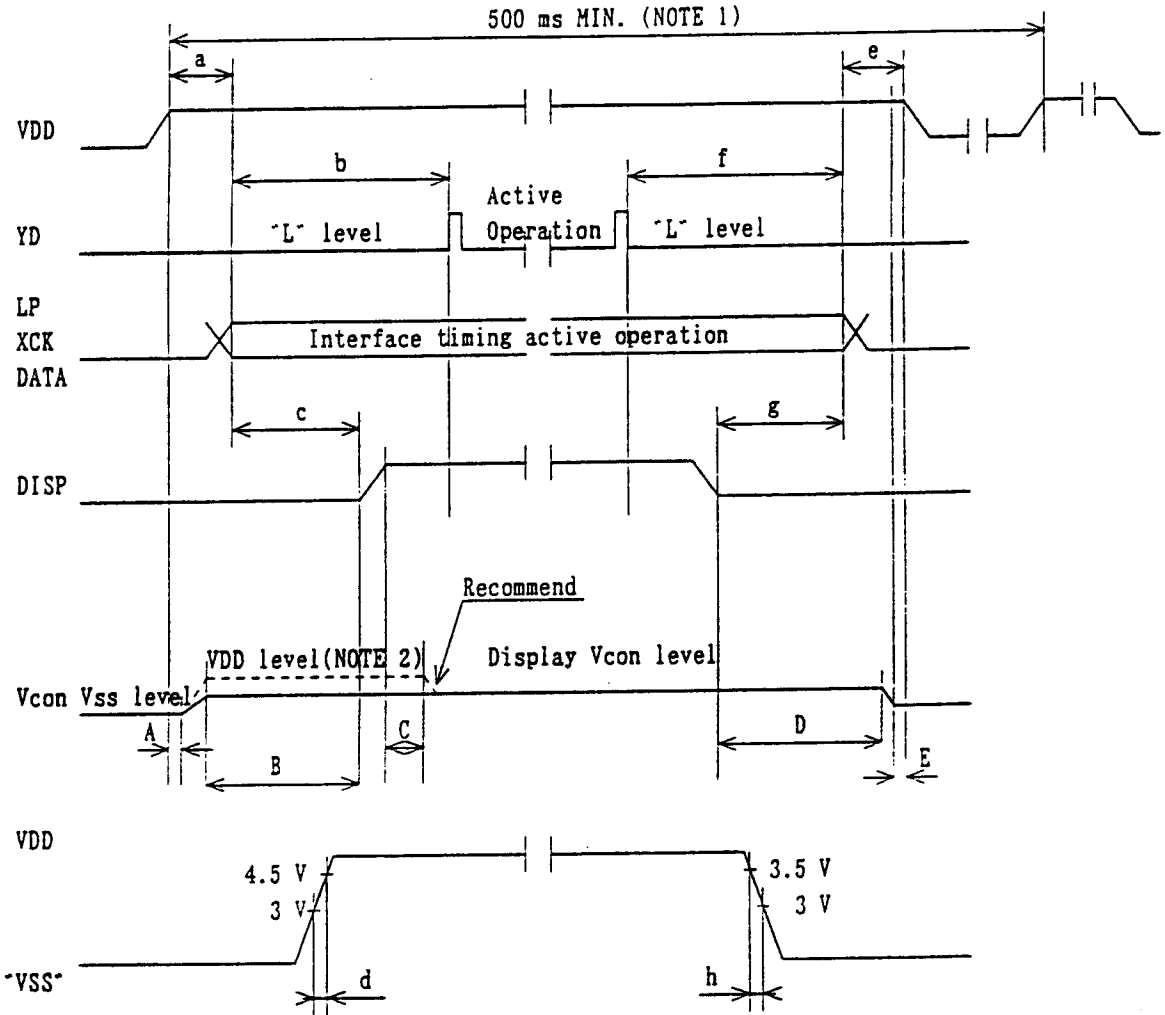

POWER ON	
SYMBOL	Allowable value
a	0 ms MIN. 1 s MAX.
b	0 ms MIN. 1 s MAX.
c	LP × 250 MIN. 1 s MAX.
d	— 25 ms MAX.
A	0 ms MIN. —
B	0 ms MIN. —
C	60 ms MIN. (NOTE 2) Recommend

POWER OFF	
SYMBOL	Allowable value
e	0 ms MIN. 1 s MAX.
f	0 ms MIN. —
g	0 ms MIN. 1 s MAX.
h	1 ms MIN. —
D	0 ms MIN. —
E	0 ms MIN. —

(NOTE 1) Power ON/OFF cycle time. All signals and power line shall be in accordance with above sequence in case of power ON/OFF.

(NOTE 2) In order to reduce the rush current, It is recommended that "Vcon" to be set to "VDD" level after power on. C(60 ms MIN.) is recommended.

7/27

SHARP

SPEC No.	MODEL No.	PAGE
LC94805B	LM64C35P	24

9. Applicable inspection standard

The LCD unit shall meet the following inspection standard
:S-U-014

10. This specification describes display quality in case of no gray scale.
Since display quality can be affected by gray scale methods, display quality shall be carefully evaluated for the usability of the LCD UNIT in case gray scale is displayed on the LCD UNIT.

WARNING

DON'T USE ANY MATERIALS WHICH EMIT FOLLOWING GAS FROM EPOXY RESIN (AMINES' HARDENER) AND SILICONE ADHESIVE AGENT (DEALCOHOL OR DEOXYM) TO PREVENT CHANGE POLORIZER COLOR OWING TO GAS.

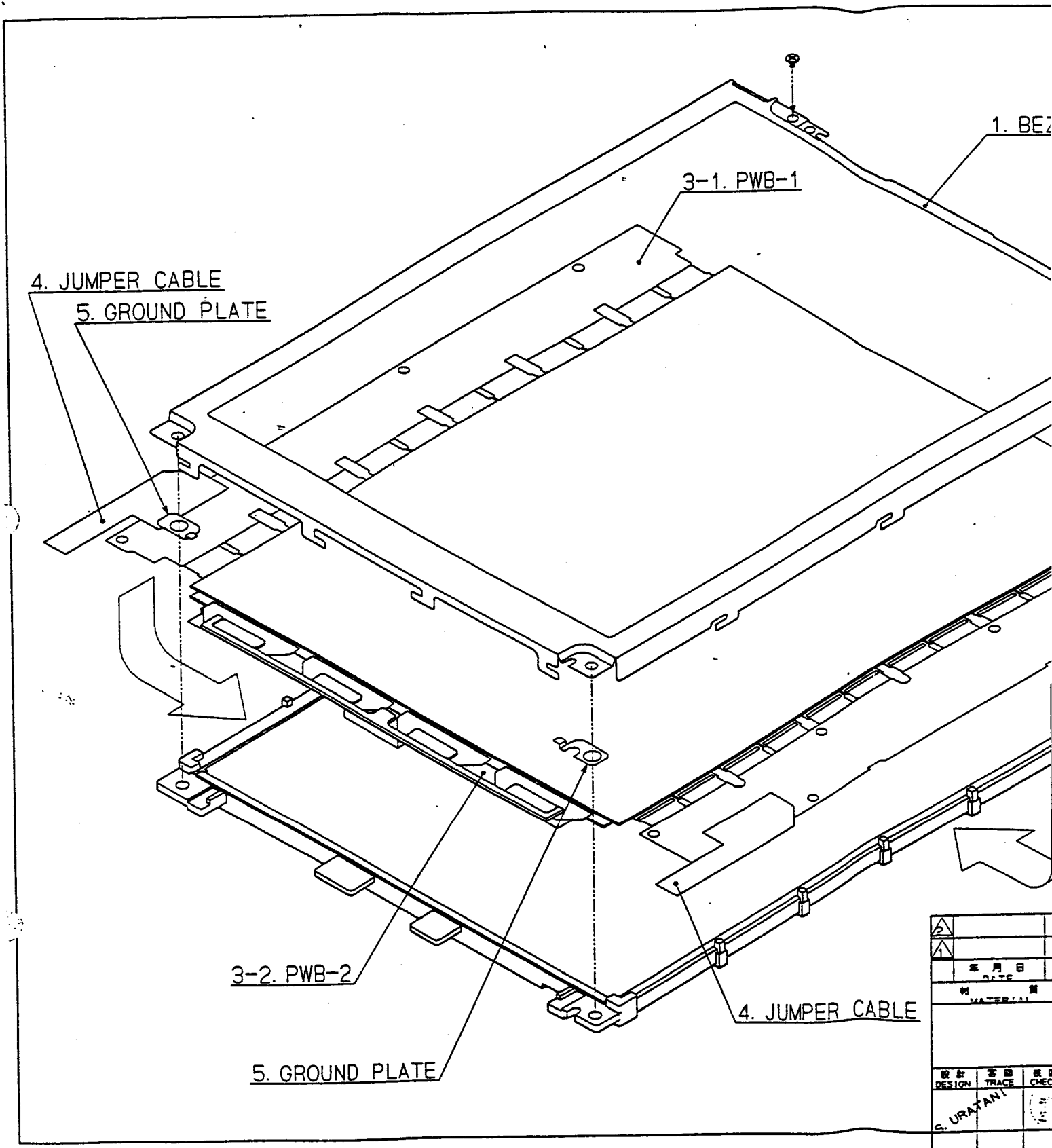

△		
△		
	年月日	DATE
	材質	MATERIAL
設計	審核	校核
DESIGN	TRACE	CHECK
S. URATANI		

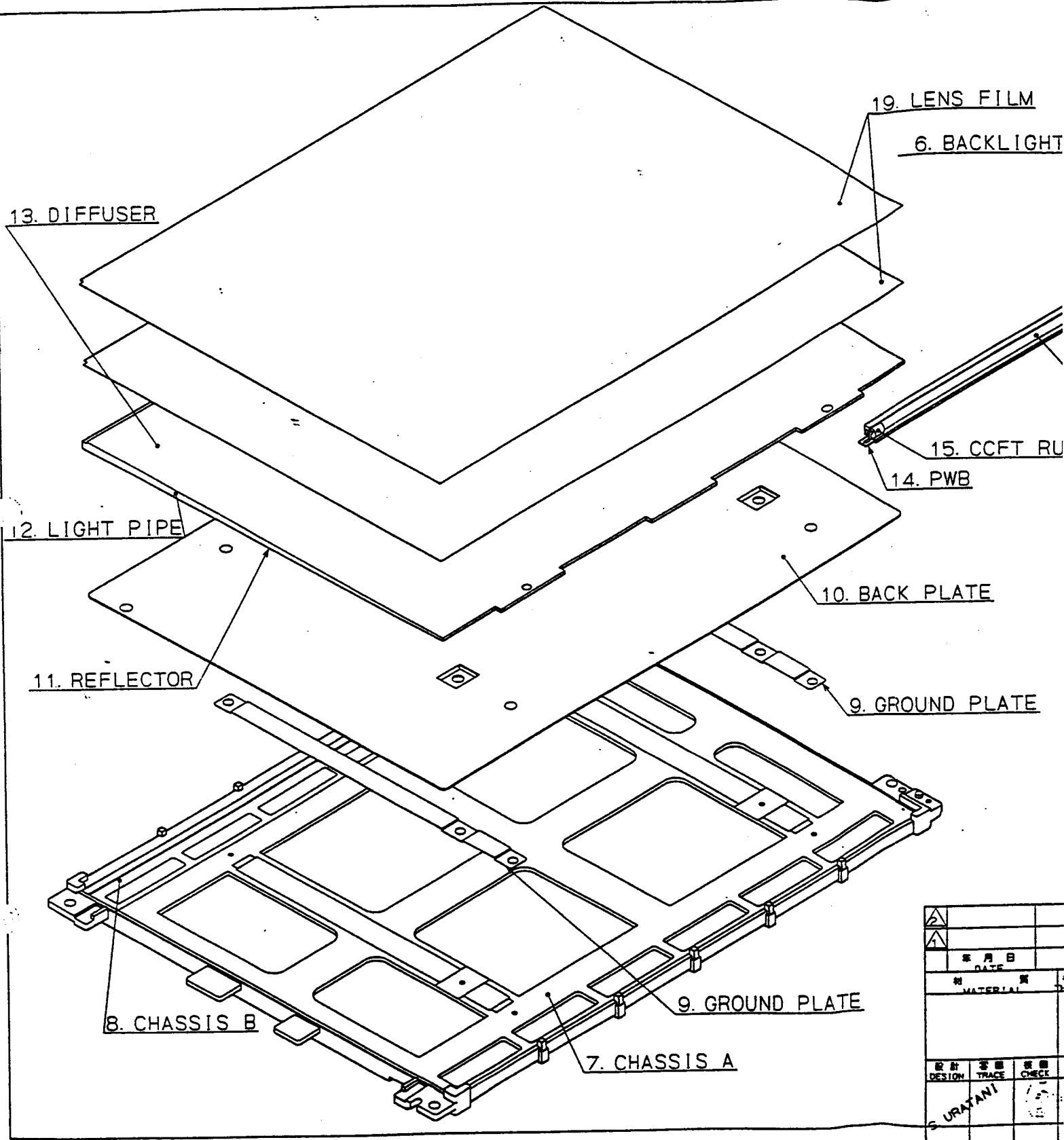

△		
△	年月日	DATE
	材料	MATERIAL
設計	確認	検査
DESIGN	TRACE	CHECK
S. URAYANI		

出図 ISSUE	
設計通知 DRAWING INFO	通知情報 INFORMATION
No. ()	発行番号 ()
新設 NEW	変更 CHANGE
増設 ADD	削除 DELETE

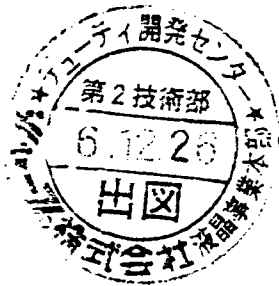
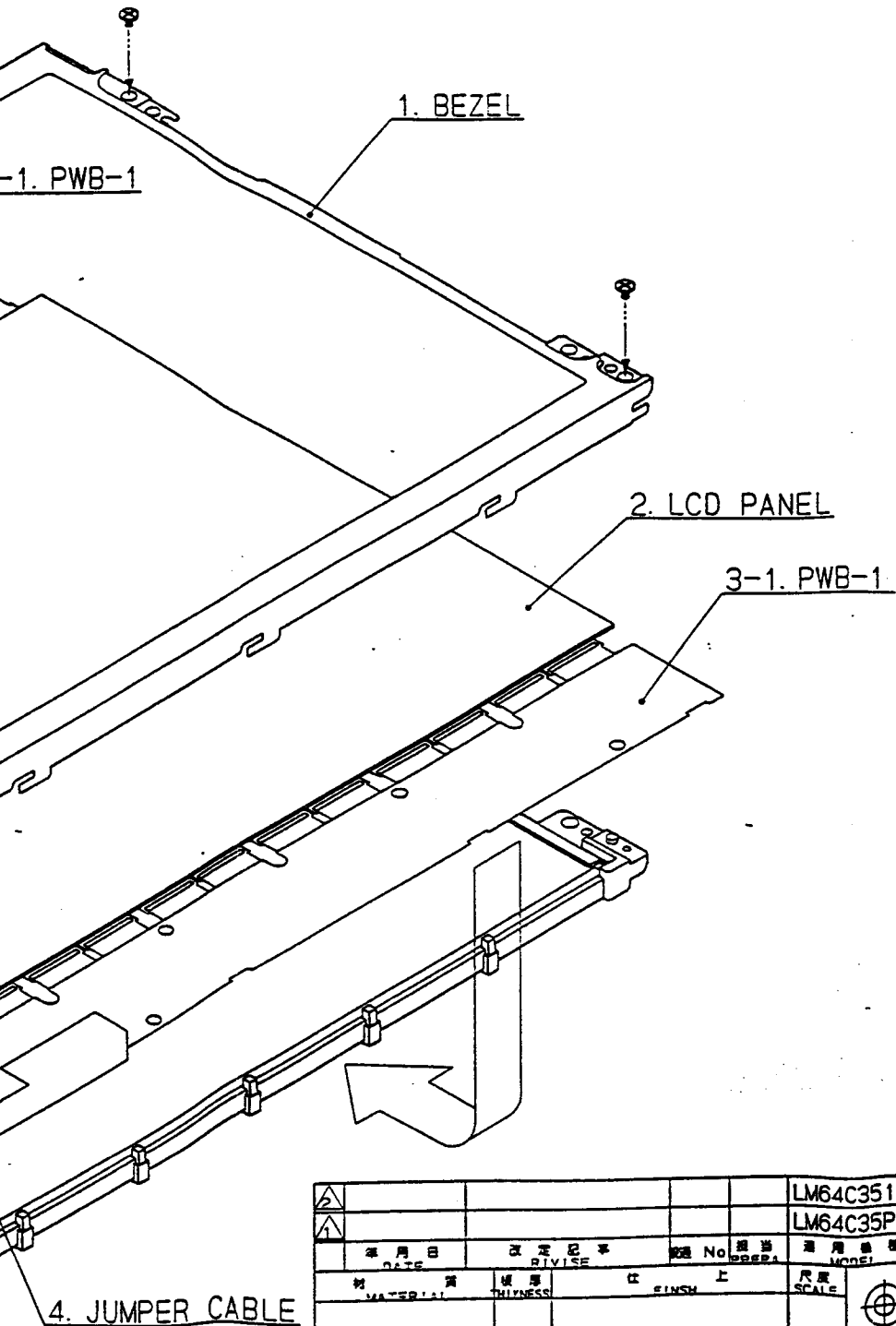

指定公差は公差は となる
UNSPECIFIED TOL TO BE

					LM64C351	名 称 NAME	Materials and component Parts list Fig.1			
					LM64C35P					
年月日 DATE	改定 REVISE	記号 No	標準 SPEC	適用 MODEL	材 質 MATERIAL	厚 度 THICKNESS	仕 上 FINISH	尺 度 SCALE	記 号 SYMBOL	部 品 代 号 PARTS CODE
設計 DESIGN	描 写 TRACE	検 査 CHECK	検 査 CHECK	承認 APPROVE	SHARP CORPORATION			作成日付 DATE	19 94 . 9 . 30 .	
S. URATANI					シャープ株式会社 液晶(事本)			部 号 DRAWING No	U:L64C35P:6:01:0	
					発行部門 コーティ開発センター第2技術部					

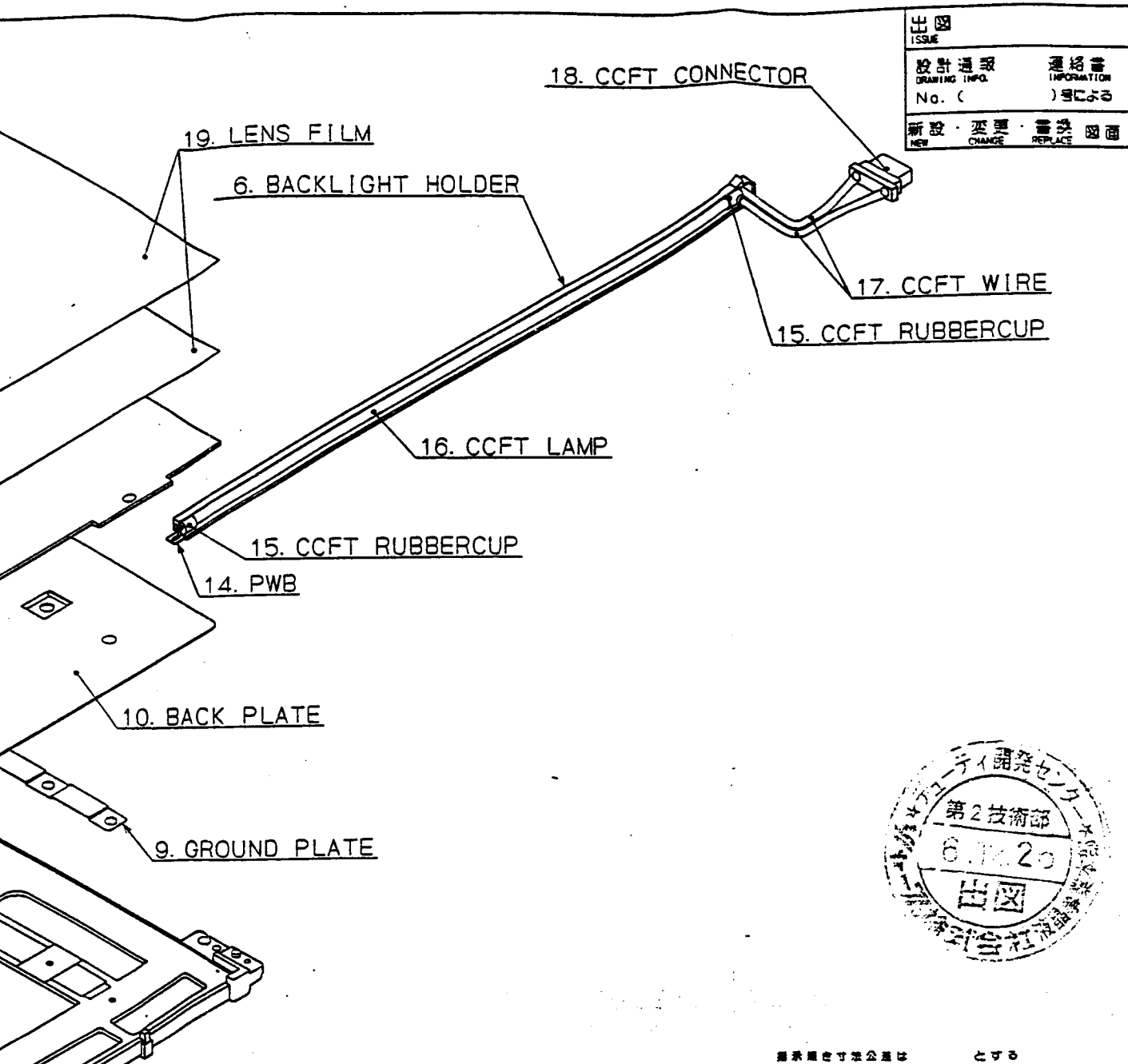

出図
ISSUE

設計情報
DRAWING INFO

No. () 号にふる

変更情報
CHANGE INFORMATION

新設・変更・置換 図面
REPLACE DRAWING

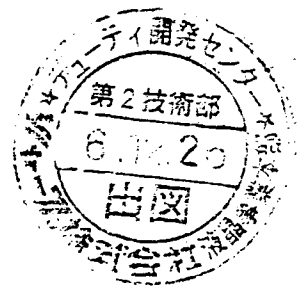

指定公差は となる
UNSPECIFIED TOL TO BE

					LM64C351	名 稱 NAME	Materials and component Parts list Fig. 2
					LM64C35P		
年月日 DATE	改定記号 REVISE	図号 DRAWING No.	担当者 PREPARED	適用機種 MODEL	記 号 SYMBOL		
材 質 MATERIAL	板 厚 THICKNESS	比 率 FINISH	上	尺 寸 SCALE	部 品 コード PARTS CODE		
SHARP CORPORATION					作 成 日 付 DATE	19 94 . 9 . 30 .	
URATANI					出 発 部 門 DRAWING No.	U.L64C35P:60:20	

